

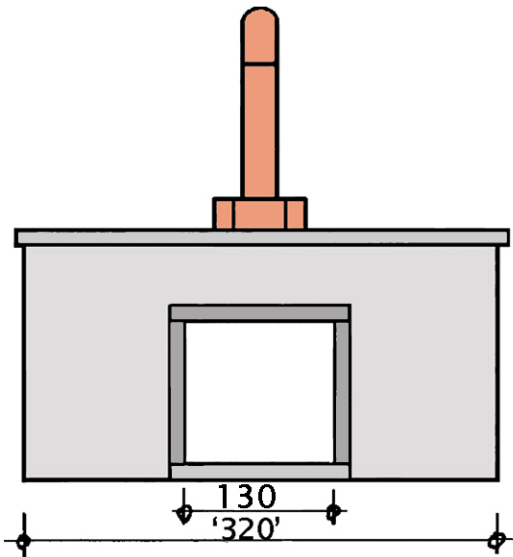

FRIENDS OF COLLIERS WOOD

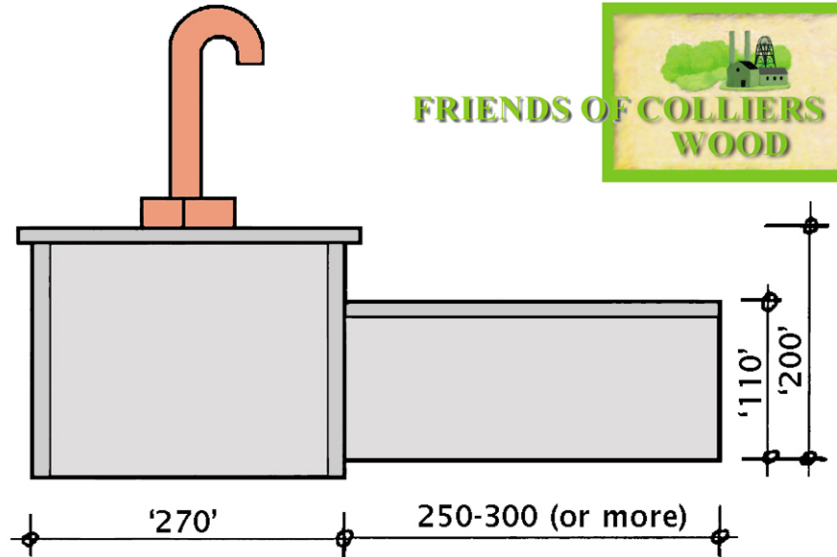

SIDE ELEVATION showing end of tunnel



END ELEVATION showing projecting tunnel

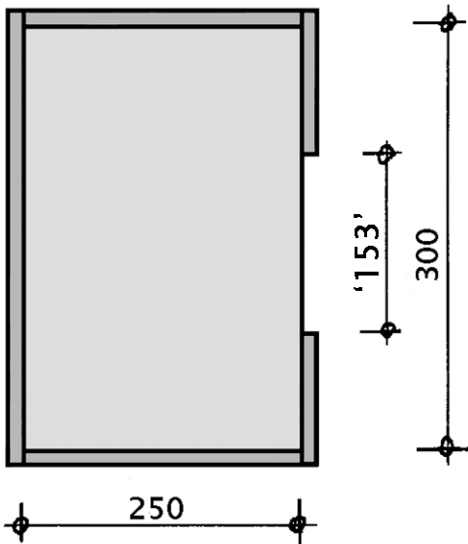

SECTIONAL PLAN without tunnel fixed

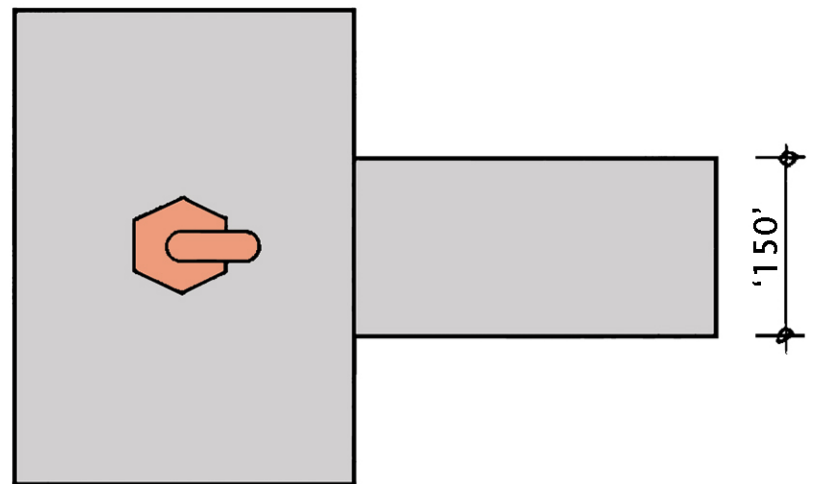

PLAN

**NOTES:**

Overall dimensions shown thus ' ' are assuming 10mm finished thickness timber. Adjust for thicker timber.  
Do not use any spirit based preservatives.  
Assembly is by galvernised nails and screws.  
Box internal dimensions can be increased but area should remain compact to retain heat.

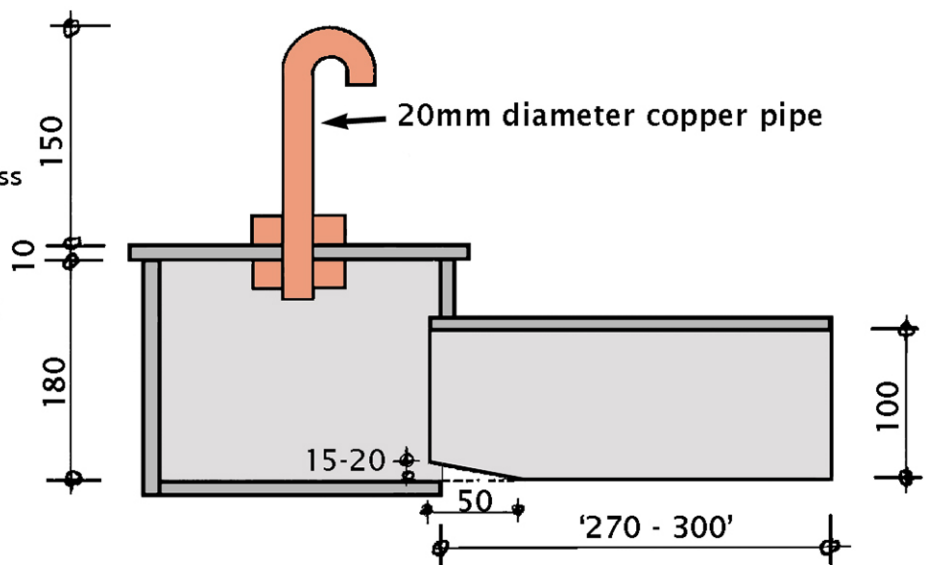

LONGITUDINAL SECTION without tunnel elevated

**HEDGEHOG HIBERNATION BOX**  
**Assembly details**

Fun with Learning Species Box scheme  
FwL - SB - H2